

## PERFORATIONS

### SOLFLO MAX

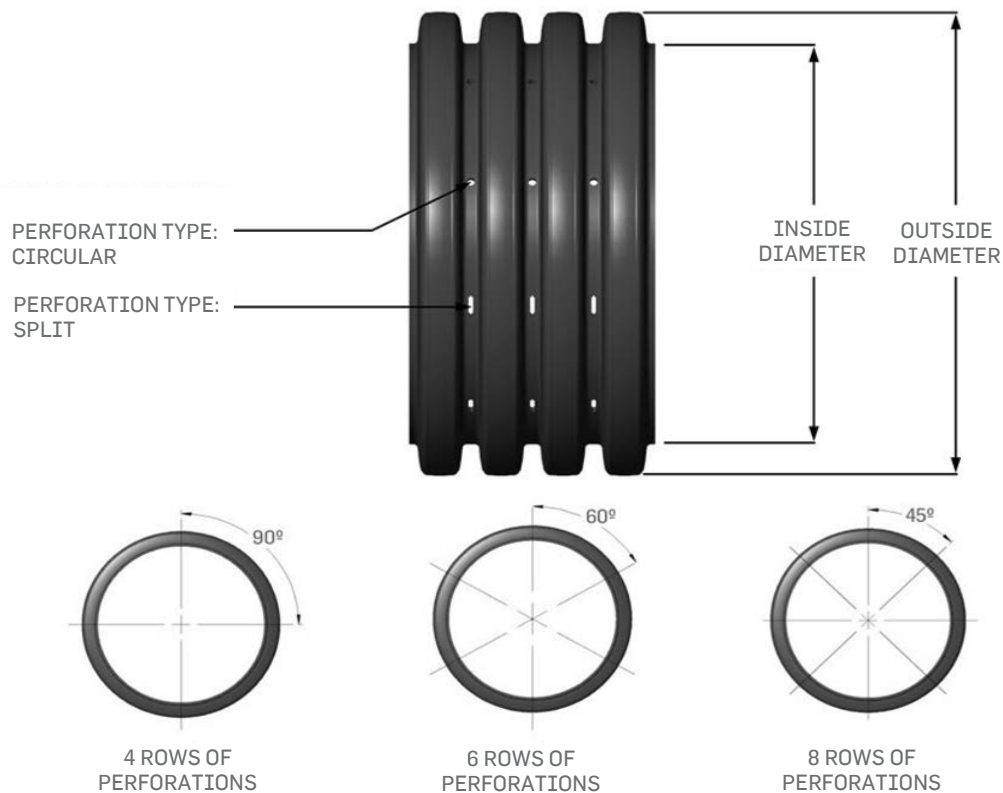

DIAMETER	ROWS OF PERF.*	PERF. / METER	PERF./ FOOT	TYPE OF PERF. SPLIT / CIRC.
100 mm (4 in)	4	236	72	Split < 55 mm (2,16 po)
150 mm (6 in)	4	196	60	
200 mm (8 in)	4	152	46	
250 mm (10 in)	4	116	35	
300 mm (12 in)	4	76	23	
375 mm (15 in)	4	52	16	
450 mm (18 in)	4	52	16	
525 mm (21 in)	4	52	16	Circular < 10 mm (0,39 po)
600 mm (24 in)	8	80	24	
750 mm (30 in)	8	80	24	
900 mm (36 in)	8	80	24	
1050 mm (42 in)	8	48	15	
1200 mm (48 in)	8	48	15	
1500 mm (60 in)	8	48	15	

\*THE NUMBER OF ROWS CAN VARY ACCORDING TO THE FACTORY AND THE AVAILABILITY OF THE PUNCHERS.

NOTE : THE MINIMUM PERFORATED AREA MUST BE AT LEAST 32 cm<sup>2</sup>/m (1.5 in<sup>2</sup> PER FOOT).