

Stormwater Management HYDROVEX® VHV / SVHV Vertical Vortex Flow Regulator



WATER TECHNOLOGIES



HYDROVEX®

VHV / SVHV Vertical Vortex Flow Regulator

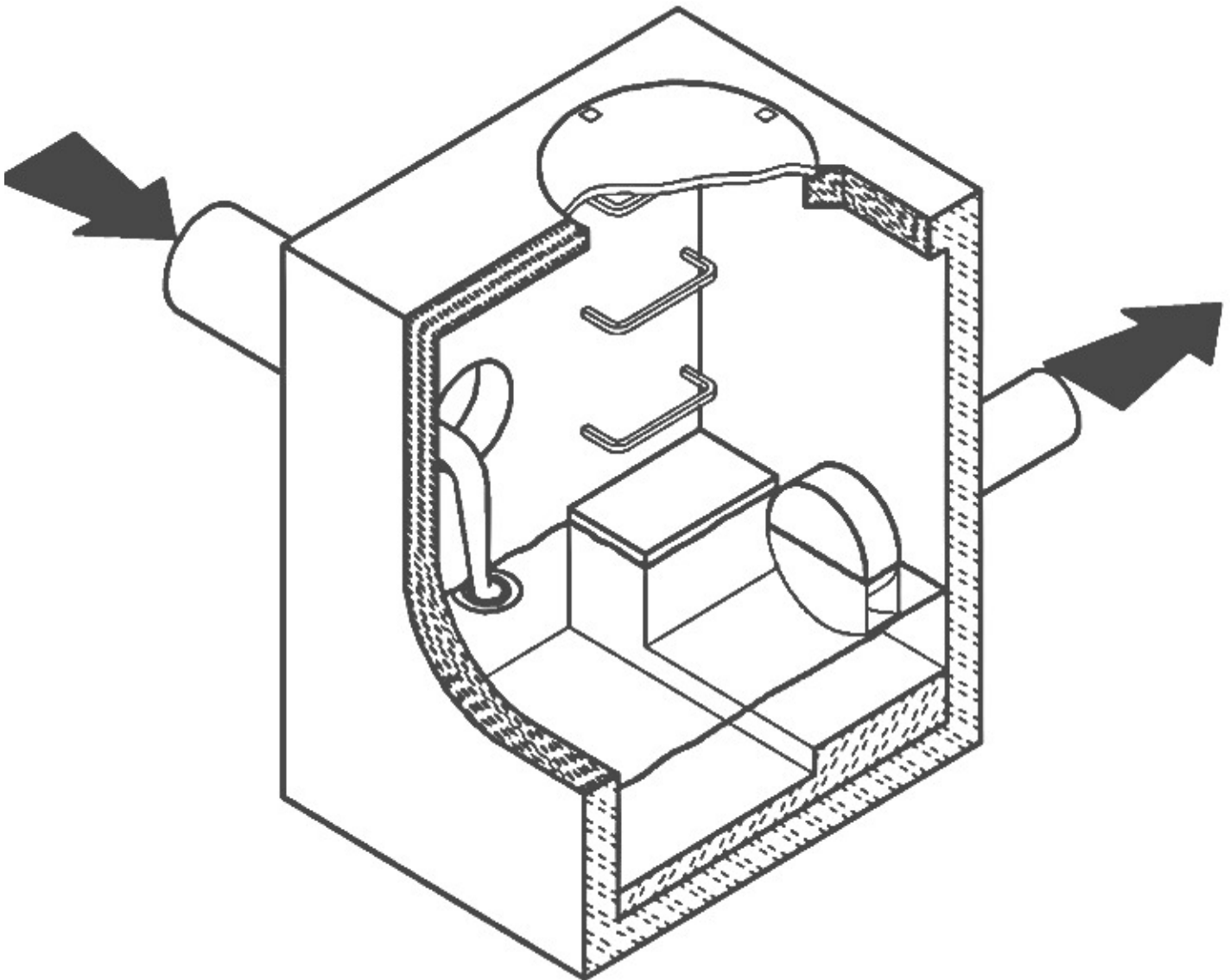

APPLICATIONS

One of the major problems of urban wet weather flow management is the runoff generated after a heavy rainfall. During a storm event, uncontrolled flows may overload the drainage system and cause flooding. Sewer pipe wear and network deterioration are increased dramatically as a result of increased flow velocities. In a combined sewer system, the wastewater treatment plant will experience a significant increase in flows during storms, thereby losing its treatment efficiency.

A simple means of managing excessive water runoff is to control excessive flows at their point of origin, the manhole. Veolia Water Technologies Canada Inc. manufactures the **HYDROVEX® VHV / SVHV** line of vortex flow regulators for point source control of stormwater flows in sewer networks, as well as manholes, catch basins and other retention structures.

HYDROVEX®

VHV / SVHV Vertical Vortex Flow Regulator

The **HYDROVEX® VHV / SVHV** design is based on the fluid mechanics principle of the forced vortex. The discharge is controlled by an air-filled vortex which reduces the effective water passage area without physically reducing orifice size. This effect grants precise flow regulation without the use of moving parts or electricity, thus minimizing maintenance. Although the concept is quite simple, over 12 years of research and testing have been invested in our vortex technology design in order to optimize its performance.

The **HYDROVEX® VHV / SVHV** Vertical Vortex Flow Regulators (refer to Figure 1) are manufactured entirely of stainless steel, and consist of a hollow body (1) (in which flow control takes place) and an outlet orifice (7). Two rubber “O” rings (3) seal and retain the unit inside the outlet pipe. Two stainless steel retaining rings (4) are welded on the outlet sleeve to ensure that there is no shifting of the “O” rings during installation and operation.

1. BODY
2. SLEEVE
3. O-RING
4. RETAINING RINGS
5. ANCHOR PLATE
6. INLET
7. OUTLET ORIFICE

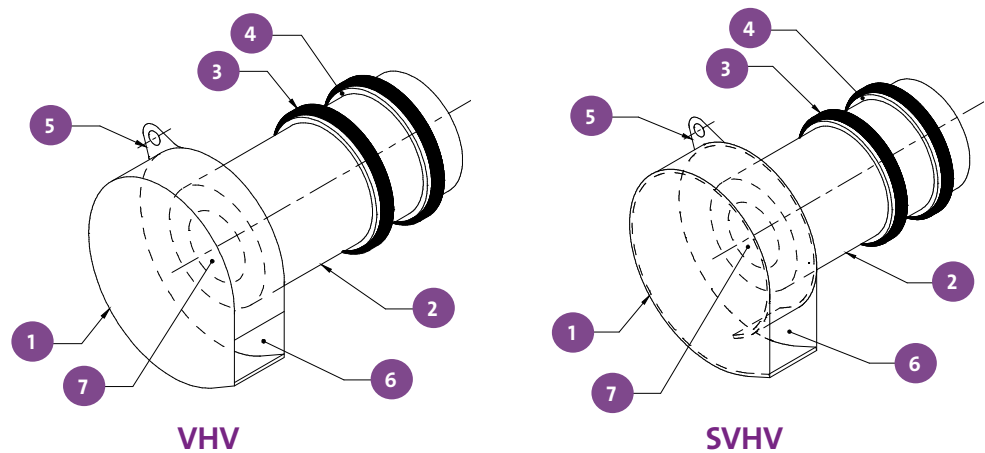

FIGURE 1: YDROVEX® VHV / SVHV VERTICAL VORTEX FLOW REGULATORS

ADVANTAGES

- The VHV / SVHV is made entirely of stainless steel. It is durable, corrosion-resistant device.
- The VHV / SVHV has no mechanical parts and therefore requires very little maintenance.
- The geometry of the VHV/SVHV allows for flow control equivalent to an orifice plate with a cross-sectional area 4 to 6 times smaller. This reduces the chances of the regulator blocking due to accumulated sediment and large debris encountered during a storm. Figure 2 shows the comparison between a Model 100 SVHV-2 regulator and an equivalent orifice plate. It can be seen that for the same water height, the regulator controls a flow rate approximately four times smaller than an equivalent orifice plate.
- Installation of the VHV/SVHV is simple and quick; it requires no special tools. It can be installed by any contractor once the civil works are completed.
- The VHV / SVHV can also be installed in existing manholes.

HYDROVEX®

VHV / SVHV Vertical Vortex Flow Regulator

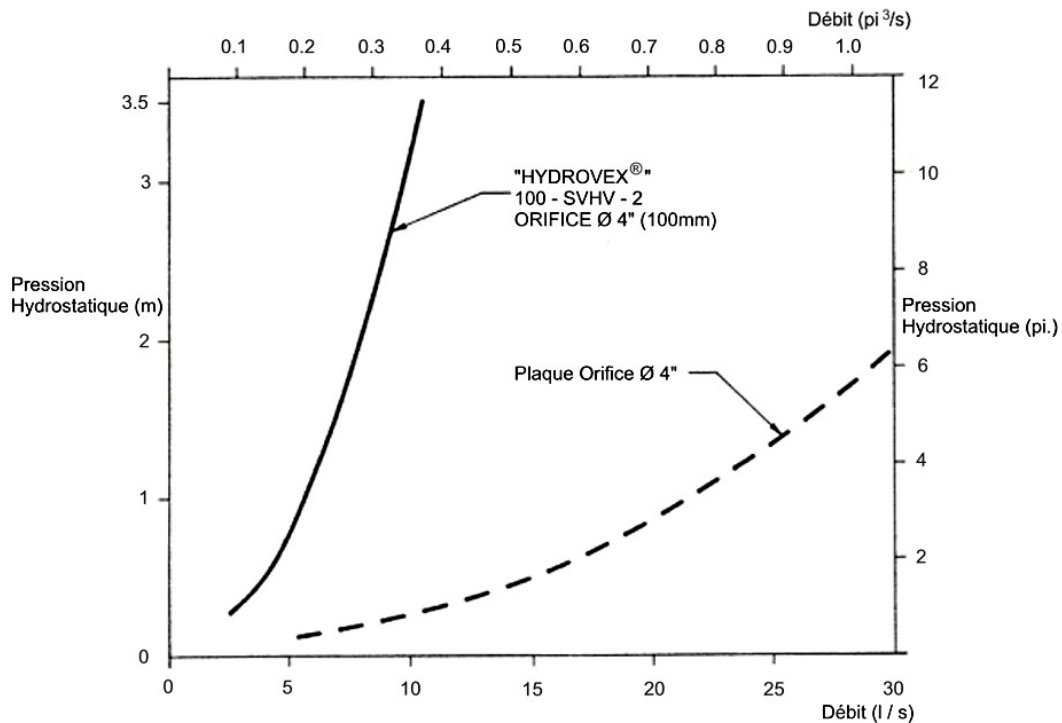

FIGURE 2: DISCHARGE CURVE SHOWING A HYDROVEX® FLOW REGULATOR VS AN ORIFICE PLATE

SELECTION

The selection of VHV or SVHV flow regulator can be easily done using the following selection tool:

app.hydrovex.com

(Please refer to page 11 for more details)

All selections must be verified by Veolia Water Technologies Canada Inc. personnel prior to manufacturing.

Example:

✓ Maximum discharge	2m		Required model: 75
✓ Maximal design head	6 L/s		

INSTALLATION REQUIREMENTS

All HYDROVEX® VHV / SVHV flow regulators can be installed in circular or square manholes. It is imperative to respect the minimum distances indicated to ensure easy installation and proper operation of the regulator.

SPECIFICATIONS

In order to specify a **HYDROVEX® VHV / SVHV** flow regulator, the following parameters must be clearly indicated:

- Model number (ex: 75-VHV-1)
- The diameter and type of outlet pipe (ex: 150mm diam. SDR 35)
- The maximum discharge rate (ex. : 6 L/s)
- The maximum upstream head (ex. : 2 m) *
- The manhole diameter (ex. : 600mm dia.)
- The minimum clearance "H" (ex. : 200mm)
- The material type (ex. : 304 stainless steel, standard).

*Upstream head is defined as the difference in elevation between the maximum upstream water level and the invert of the outlet pipe where the **HYDROVEX®** flow regulator is to be installed.*

When requesting a quote, we simply ask that you provide us with:

- Flow rate
- Water head
- Diameter and type of the chamber outlet pipe



Typical HYDROVEX® VHV model

HYDROVEX®

VHV / SVHV Vertical Vortex Flow Regulator

OPTIONS



FV - VHV

Mounted on sliding plate for emergency bypass



VHV - GN

With Gooseneck assembly (manhole without clearance below regulator)



VHV - V

With upstream air vent (applications where outlet pipe is >80% full)

HYDROVEX® VHV / SVHV Vertical Vortex Flow Regulator

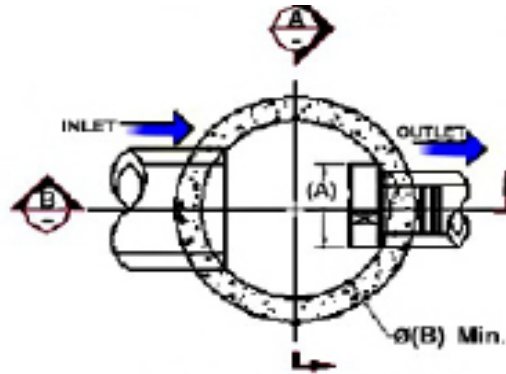

CIRCULAR MANHOLE

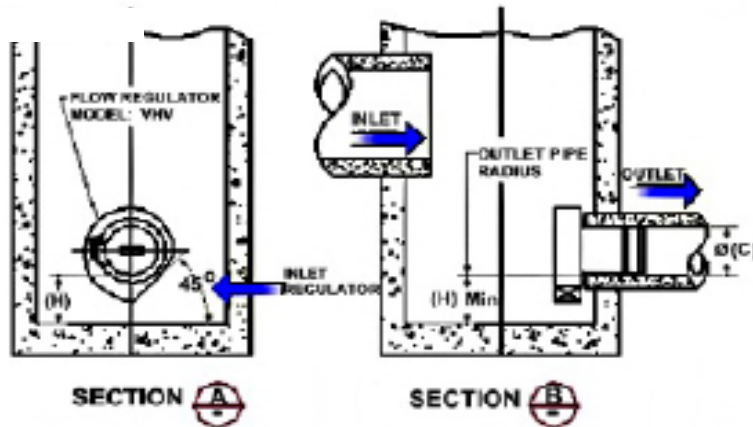

SECTION A

SECTION B

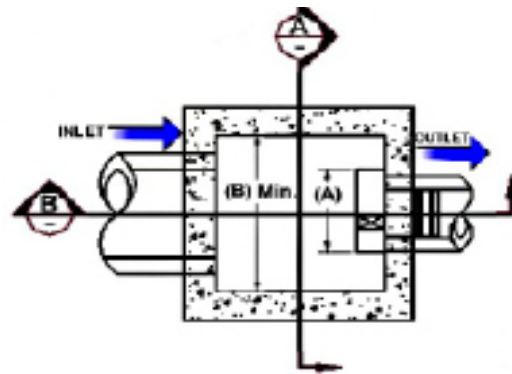

SQUARE / RECTANGULAR WELL

SQUARE MANHOLE

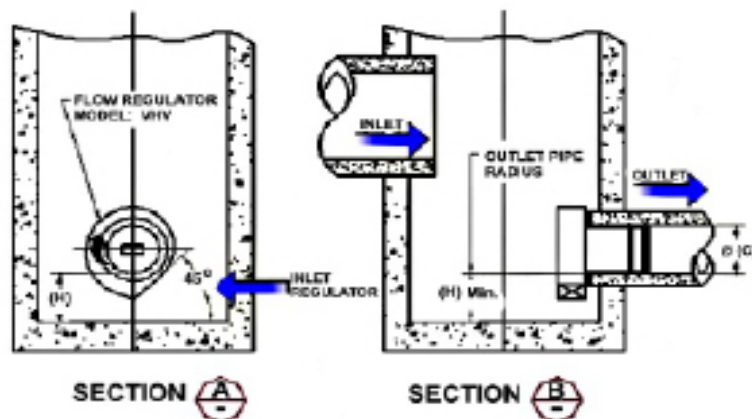

SECTION A

SECTION B

HYDROVEX®

VHV / SVHV Vertical Vortex Flow Regulator

MATERIALS

Given the particularly corrosive environment in which these valves are installed, we paid particular attention to the choice of materials used in their construction.

Parts that come into direct contact with wastewater are made of PVC or stainless steel. All mechanically stressed parts, such as the threaded rod, nut, and bolts, are made of stainless steel and bronze.

INSTALLATION

The **HYDROVEX® VHV / SVHV** flow regulator is installed with the manhole in place. Simply fit the regulator sleeve inside the outlet pipe. Veolia Water Technologies Canada Inc. recommends applying lubricant to the O-rings and the inside wall of the outlet pipe to facilitate insertion and orientation of the regulator.

INSTALLATION PROCEDURE

Unit Description

The model number provides important details required for installing the **HYDROVEX®** Flow Regulator, for example: **100VHV-2 (STD, OF, SA)**

- The number 100 indicates the opening in millimeters of the **HYDROVEX®**
- STD indicates standard model
- OF indicates counter-flange model
- SA indicates special adapter

Preparing for installation

The regulator outlet pipe must be clean and thoroughly cleaned before installation. The **HYDROVEX®** Flow Regulator is delivered ready for installation. It can be lowered into the manhole using a rope or cable.

Installing the **HYDROVEX®** Flow Regulator

The **HYDROVEX®** Flow Regulator outlet pipe is inserted into the manhole outlet pipe. The anchor is inserted into the anchor point, located on top of the regulator.

Note: Proper operation of the **HYDROVEX®** vortex regulator can only be ensured if it has been properly installed.

Anchor Installation

1. Using a suitable drill bit, drill a hole in the base material to a depth of at least 12.7 mm (0.5 in.) or one anchor diameter deeper than the required embedment.
2. Ensure the hole is clean and free of dust or other materials.
3. Position the washer over the anchor point and the thread over the nut.
4. Insert the anchor into the intended anchor hole until the washer and nut are firmly seated on the anchor point. Ensure the anchor is inserted to the required depth.
5. Tighten the anchor by turning the nut 3 to 4 turns.

Size	Drill Diameter	Minimum Installation Depth	Thread Length
3/8" x 5"	3/8"	1 5/8"	3 3/4"

MAINTENANCE

HYDROVEX® flow regulators are designed and manufactured to minimize maintenance requirements. We recommend a periodic visual inspection every 3-6 months (depending on local flow and sediment conditions) in order to ensure that neither the inlet nor the outlet has become blocked with debris. The manhole housing the vortex regulator should be inspected and cleaned with a vacuum truck periodically, especially after major storm events.

Inspection

The **HYDROVEX®** flow regulator controls flow autonomously and does not require manual or external intervention to operate. Visual inspections are recommended, especially during start-up or upon completion of work upstream of the chamber. The maintenance schedule below includes recommended service intervals.

Maintenance Interval	Maintenance Procedure
Three (3) months after commissioning and following the first storm	- Visual inspection - Inspect the regulator inlet and remove any debris, if any
Then, every six (6) months	As above

The **HYDROVEX®** flow regulator is not a waste disposer. Waste that is wider than the outlet opening can become trapped in the regulator due to its length. This type of debris must be manually removed when detected. This debris can cause malfunctions.

A complete inspection is recommended once a year, including cleaning the sight glass and a visual inspection for anomalies such as leaks and cracks on the unit.

HYDROVEX®

VHV / SVHV Vertical Vortex Flow Regulator

GUARANTY

The **HYDROVEX®** line of VHV / SVHV regulators are guaranteed against both design and manufacturing defects for a period of 5 years after sale. Should a flow regulator be found to be defective within the guarantee period, Veolia Water Technologies Canada Inc. will modify or replace the defective unit.

The manufacturer, Veolia Water Technologies Canada Inc., warrants this flow regulator against any manufacturing defects or failure when installed and used under the conditions for which it was originally designed and sold. This warranty is for 5 years from the date of delivery.

Veolia Water Technologies Canada Inc. guarantees that the flow rate as measured under original installation conditions must not exceed by more than 5% the flow rate shown on the certified curve supplied with the regulating valve.

Caution: Please do not confuse the guaranteed accuracy of the selection curve issued by Veolia Water Technologies Canada Inc., $\pm 5\%$ of the flow rate, with the accuracy of the readings taken during testing, generally $\pm 15\%$ of the flow rate. The $\pm 5\%$ accuracy of our curve is a result of the quality of the calibration tests performed by independent laboratories and the calculation method used during selection. Therefore, for a given field test, a generated point showing a flow rate within $\pm 20\%$ of the Veolia Water Technologies Canada Inc. curve is acceptable and conclusive due to the accuracy of the available methods.

HYDROVEX® flow regulators must be installed according to the recommendations of Veolia Water Technologies Canada Inc.

This warranty will be voided if repairs or modifications to the equipment are made without the authorization of Veolia Water Technologies Canada Inc.

If necessary, Veolia Water Technologies Canada Inc. will be solely responsible for repairs or complete replacement of the **HYDROVEX®** regulator but will not be responsible in whole or in part for any handling or installation incurred as a result of these repairs.

FLOW REGULATOR SELECTION TOOL

Link to access the flow regulator selection tool:

app.hydrovex.com

Steps :

1. Create an account
2. Complete the registration form
3. Click on the link in the confirmation mail
4. Access the selection tool
5. Click on “New project”
6. Complete the information in the mandatory fields, validate and save
7. Click for an option:
 - a. display the curve
 - b. export CSV
 - c. generate the technical sheet
 - d. make price request

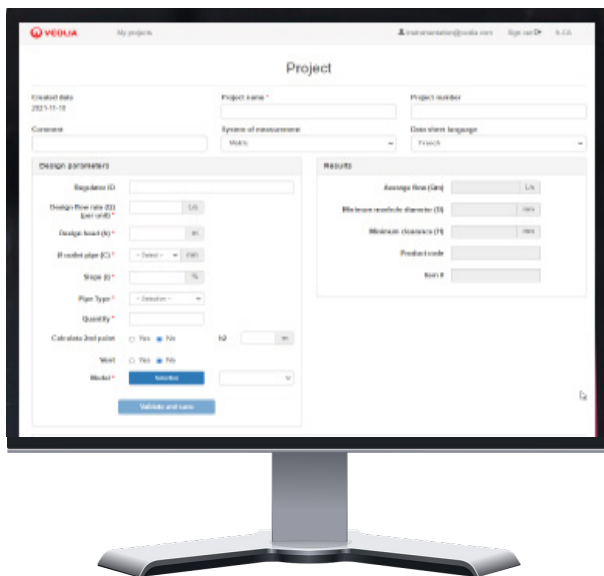

DATA SHEET
HYDROVEX® VHV
VORTEX REGULATOR

GENERAL INFORMATION

Application: Stormwater
 Project name: 10150 HENRI-BOURASSA, MONTREAL-EST, QC
 Project number: _____
 Comment: _____
 Regulator ID: R-4
 Design flow (Q): 10.1 L/s
 Design head (h): 1.1 m
 Outlet pipe diameter (C): 150 mm
 Outlet pipe type: PVC
 Model: 100 VHV-1,6,SA,V
 item #: PRIPHY200360
 Quantity: 1
 Minimum clearance (H): 200 mm
 Minimum manhole diameter (B): 900 mm

RATING CURVE

Q (L/s)	h (m)
0.000	0.009
2.392	0.076
5.554	0.142
6.768	0.209
6.638	0.276
5.782	0.342
6.206	0.409
9.988	1.075
12.732	1.742
14.981	2.408
16.935	3.075
18.685	3.741
27.352	8.007
35.311	13.339

Ressourcing the world

Veolia Water Technologies

4105 Sartelon Street, Saint-Laurent, Québec H4S 2B3

Tel: 514-334-7230 · Fax: 514-334-7519

cso@veolia.com . www.veoliawatertechnologies.ca