

DATA SHEET

DRAINAGE OUTLET

PRODUCT DESCRIPTION : Assembly of a non-perforated rigid dual wall pipe, with smooth interior and corrugated exterior walls and a stainless steel fork grate at the end, for roadway use

FUNCTION : Assembly allowing gravity flow of water and preventing animals and debris from clogging the outlet

RAW MATERIALS : Made from high-density polyethylene (HDPE) ASTM D3350
304 stainless steel grate, nuts, washers, hinge and bolts
PVC adhesive tape

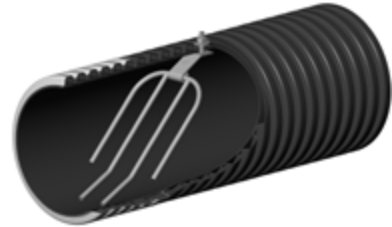

DRAINAGE OUTLET

TECHNICAL DATA : Diameters : 100 mm (4 in) to 250 mm (10 in)
Length : 3.0 m (9.8 ft)
Strength in compression : 320 kPa
Structural strength: CAN/CSA - S6 - 02 (CL-625), AASHTO (H-25 and HS-25) and AREMA Cooper (E-80)
Manning : 0.010 to 0.012
Coupler : double bell snap (DBS)

APPLICATION : Drainage collector and outlet

TECHNICAL DATA TABLE

Pipe								Stainless steel fork grate														
Nom. dia.		Int. dia.		Ext. dia.		Length		A		B		C		E		F		H		I	Stem Dia. J	
mm	in	mm	in	mm	in	m	ft	mm	in	mm	in	mm	in	mm	in	mm	in	mm	in	Degree	mm	in
100	4	101	4.0	120	4.7	3.0	9.8	32	1.26	73	2.87	N/A	N/A	92	3.62	N/A	N/A	137	5.39	157	6	0.24
150	6	150	5.9	176	6.9	3.0	9.8	36	1.42	102	4.02	N/A	N/A	137	5.39	N/A	N/A	195	7.68	157	6	0.24
200	8	205	8.1	236	9.3	3.0	9.8	37	1.46	105	4.13	159	6.26	178	7.01	228	8.98	265	10.43	158	6	0.24
250	10	251	9.9	296	11.7	3.0	9.8	44	1.73	134	5.28	191	7.52	235	9.25	300	11.81	344	13.54	158	6	0.24

Note 1 : Values in the table are approximate and may change without notice.

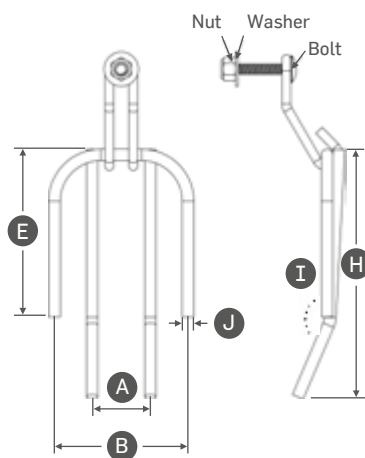

100 mm (4 in) and 150 mm (6 in)

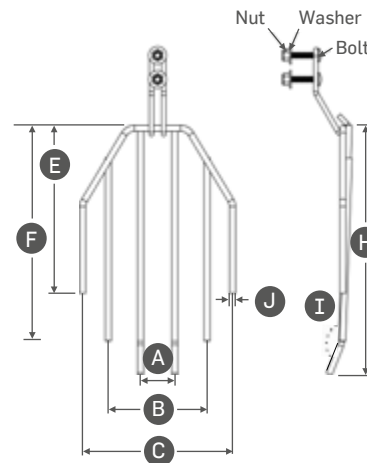

200 mm (8 in) and 250 mm (10 in)