

RECYFIX AND TOP X CHANNEL

INSTALLATION GUIDE

TRENCH DRAIN SYSTEMS INSTALLATION INSTRUCTIONS

STEPS

1. Trench preparation
2. Connection(s) and installation

Installation on concrete foundation

- 2.1 Installation on concrete foundation
- 2.2 Setting up drainage channel
- 2.3 Backfill

Installation on concrete pad (patties)

- 2.1 Installation of concrete pad (patties)
- 2.2 Setting up drainage channel
- 2.3 Concrete surround

3. Surface finishing

BEFORE UNDERTAKING THE WORK

If there is a difference between the information contained in this guide and that in the plans and specifications, contact your Soleno representative.

Upon receipt of goods, inspect and ensure that none of them are damaged or missing. Contact your Soleno representative at least 48 hours before the start of the work. The visit of a representative authorized by Soleno is recommended after receipt of the products at the site or before the start of the work.

Before starting the installation, the contractor must have in hand the correct Installation Cross Section Drawing according to the model and size of the trench drain, the loading requirement and the surface finish.

TOOLS

Levelling, cutting and drilling

- String line and/or survey equipment
- Drill with drill bits and/or hole saw
- Knife
- Handsaw, jigsaw, angle grinder (for cutting in plastic materials)

Setting up

- Compaction equipment
- Ready-mix concrete, trowel and vibrator
- Rubber mallet and wooden block
- Wrench and screwdriver
- Malleable sealant (Solenos recommends the use of Sika No. 714 sealant or equivalent)

STEP 1 : TRENCH PREPARATION

- Excavate the trench according to the dimensions of the channel, depth of concrete base, width of concrete encasement and finished surface level.
- Prepare the string line and/or survey equipment to establish the appropriate alignment and level. Ensure that the edge of the drainage channel will be between 3 and 5 mm below the adjoining surface finishes.
- Level the bottom of the trench and compact it well.
- A layer of clean concrete can be poured at the bottom of the trench to create a flat, clean surface.

STEP 2 : CONNECTION(S) AND INSTALLATION

The connections, whether vertical (under the gutter) or horizontal (on the end caps, at the ends), must be drilled on site. The preformed outlets are in metric format versus our pipes which are in imperial format. This implies the need to use adapters, according to the following table.

Hauraton	Connection type	Connection diameter		Connection detail
		mm	po	
TOP X	DRAIN	100	4	Reducer Soleno 4-3in 1R0043 + Installation kit HAU44343
	SOLFLO MAX	100	4	Double bell Soleno 3MCC004C or 3MCC004GI
	PVC	100	4	Installation kit Soleno HAU44343
RECYFIX	DRAIN	100	4	Double bell Soleno 3MCC004C
	SOLFLO MAX	100	4	Double bell Soleno 3MCC004C or 3MCC004GI
	PVC	100	4	Double bell PVC Soleno HAU928
	SOLFLO MAX	150	6	Double bell Soleno 3MCC006C or 3MCC006GI
	PVC	150	6	Female end PVC DR35
	PVC	200	8	Female or male end PVC DR35

Consult the typical drawing of the drainage channel for the maximum diameter and the position of the connection.

INSTALLATION ON CONCRETE FOUNDATION

STEP 2.1 : INSTALLATION ON CONCRETE FOUNDATION

Pour the concrete base according to the dimensions indicated in the Installation Cross Section Drawing. Concrete base can be applied as semi-Dry Base (Low Slump) or Wet-Mix Base (High Slump) concrete, depending on project requirements and load class.

Semi-Dry Base (Low Slump)

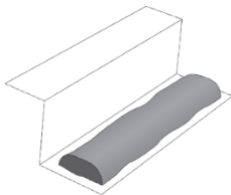

Wet-Mix Base (High Slump)

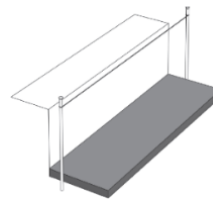

STEP 2.2 : SETTING UP THE DRAINAGE CHANNEL

- Clean the drainage channel mating ends. If required, apply a bead of malleable sealant (Sika No. 714 sealant or equivalent) on the female end of the channel to "press and seal" the male end. Please refer to the project designer instructions.
- The drainage channel sections must be laid from downstream to upstream using the position of the outlet as the starting point. The arrow affixed on it indicates the direction of the flow and must be pointing the outlet. **The HAU31110 galvanized steel cover must be installed on the HAU47100 channel on construction site before installation in the trench**
- Install the channel sections one after the other by sliding them down onto the assembly of an already installed channel section. Male and female ends have a tongue and groove joint.
- Lay the sections on the foundation ensuring the correct level and alignment. To correct level or alignment, make minor adjustments using a rubber mallet or adding concrete / mortar under the channel section.
- Apply "Low Slump" concrete coating to securely fix the drainage channel sections in place after they have been installed in the correct position. The grate should be kept in place and covered on the drainage channel while pouring concrete.

STEP 2.3 : BACKFILL

- Wait until the concrete around the base of drainage channel has dried (cured) properly before performing the final backfill and surface finish.
- Place the backfill in accordance with the installation cross section. Check that the backfill material is well compacted to avoid settling and that the top of the drainage channel will be between 3 and 5 mm below the final level.

INSTALLATION ON CONCRET PADS (PATTIES)

The concrete pads will support the drainage channel during installation to allow the concrete surround to be completed in a single pour (under and on the sides of the drainage channel).

STEP 2.1 : INSTALLATION ON CONCRETE PADS (PATTIES)

- Install semi-dry (low slump) concrete pads by spacing them along the trench base. The concrete pads shall be placed at both ends of each trench drain unit.
- The concrete pads will be used to support and raise the trench drain units at the required height.

STEP 2.2 : SETTING UP THE DRAINAGE CHANNEL

- Clean the drainage channel mating ends. If required, apply a bead of malleable sealant (Sika # 714 sealant or equivalent) on the female end of the channel to "press and seal" the male end. Please refer to the project designer instructions.
- The drainage channel sections must be laid from downstream to upstream using the position of the outlet as the starting point. The arrow affixed on it indicates the direction of the flow and must be pointing the outlet.
- Install the channel sections one after the other by sliding them down onto the assembly of an already installed channel section. Male and female ends have a tongue and groove joint.

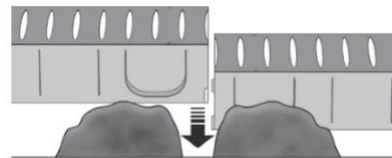
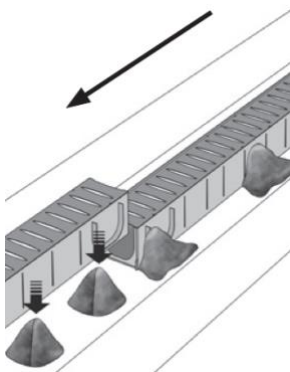

- Lay the sections on the footings ensuring the correct level and alignment. To correct level or alignment, make minor adjustments using a rubber mallet or adding concrete / mortar under the channel section.
- Apply "Low Slump" concrete to securely fix the drainage channel sections in place after they have been installed in the correct position. The grate should be kept in place and covered on the drainage channel while pouring concrete.

STEP 2.3 : CONCRETE SURROUND

- The concrete pads must be sufficiently hardened (cured) before placing the concrete surround.
- Pour concrete under and around drainage channel sections. Use a concrete vibrator to remove air bubbles in concrete mix. The grate should be kept in place and covered on the drainage channel while pouring concrete).

STEP 3 : SURFACE FINISHING

- It is recommended that a sturdy construction tape be placed on the drainage channel grates to prevent concrete, asphalt or site debris from entering the system during installation.

Hot mix asphalt surface

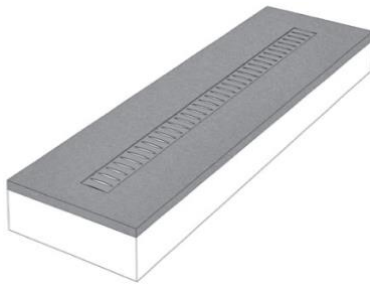

Paving-stone surface

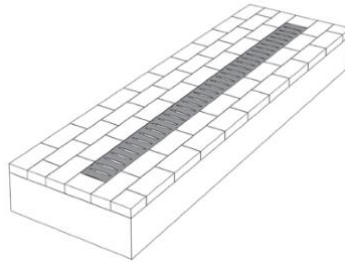

Concrete pavement surface

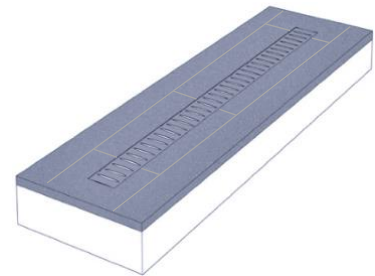

- Visit www.soleno.com to find the applicable Installation Cross Section Drawing for the dimensions and model of the drainage channel, the load class and the intended surface finish. See below, for additional details.

TOP X

- Paving-stone, Class A15 *See detail 1*
- Large paving block, Class A15 *See detail 1*

RECYFIX PRO and/or NC

- Paving-stone, Class A15 to B125 *See detail 1*
- Paving-stone, Class C250 *See detail 1*
- Hot mix asphalt pavement, Class D400 to E600 *See detail 2*
- Hot mix asphalt pavement, Class A15 to B125 *See detail 2*
- Hot mix asphalt pavement, Class C250 *See detail 2*
- Concrete pavement, Class A15 to C250 *See detail 3*
- Concrete pavement, Class D400 to D600 *See detail 3*

STEP 3 : FINISHING (SUITE)

DETAIL 1 : PAVING-STONE PAVEMENT

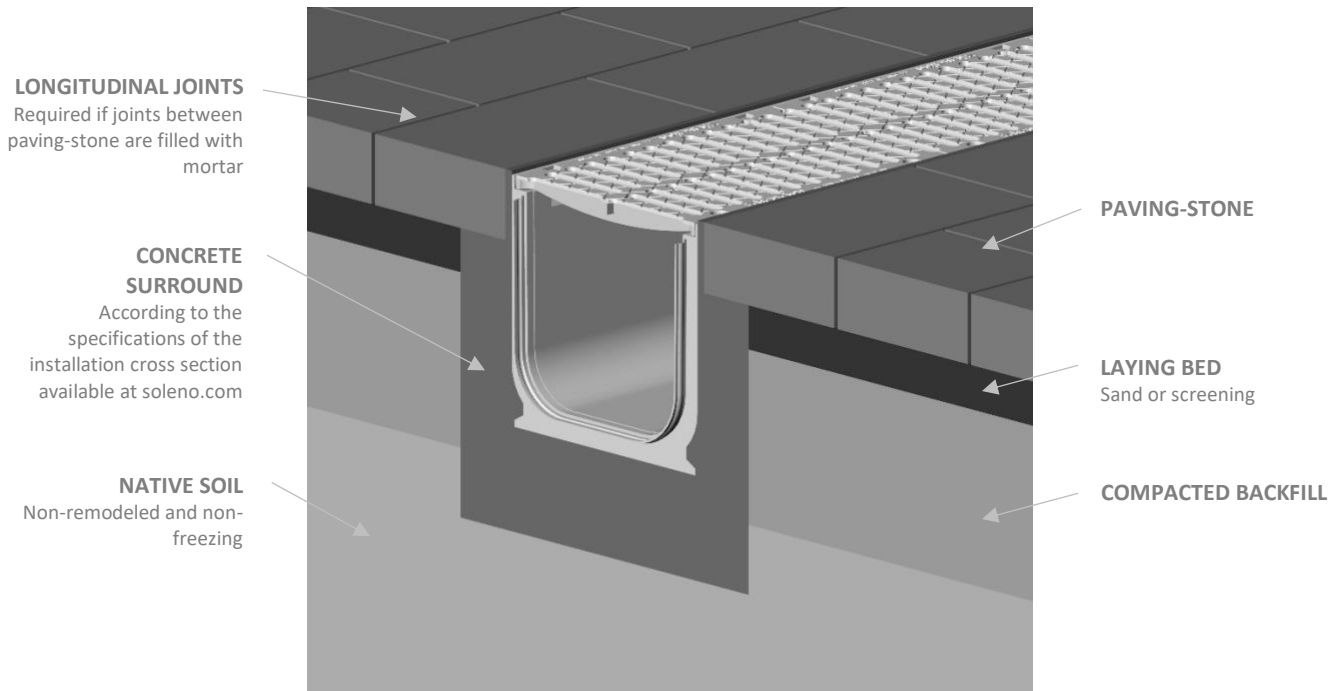

DETAIL 2 : HOT MIX ASPHALT PAVEMENT

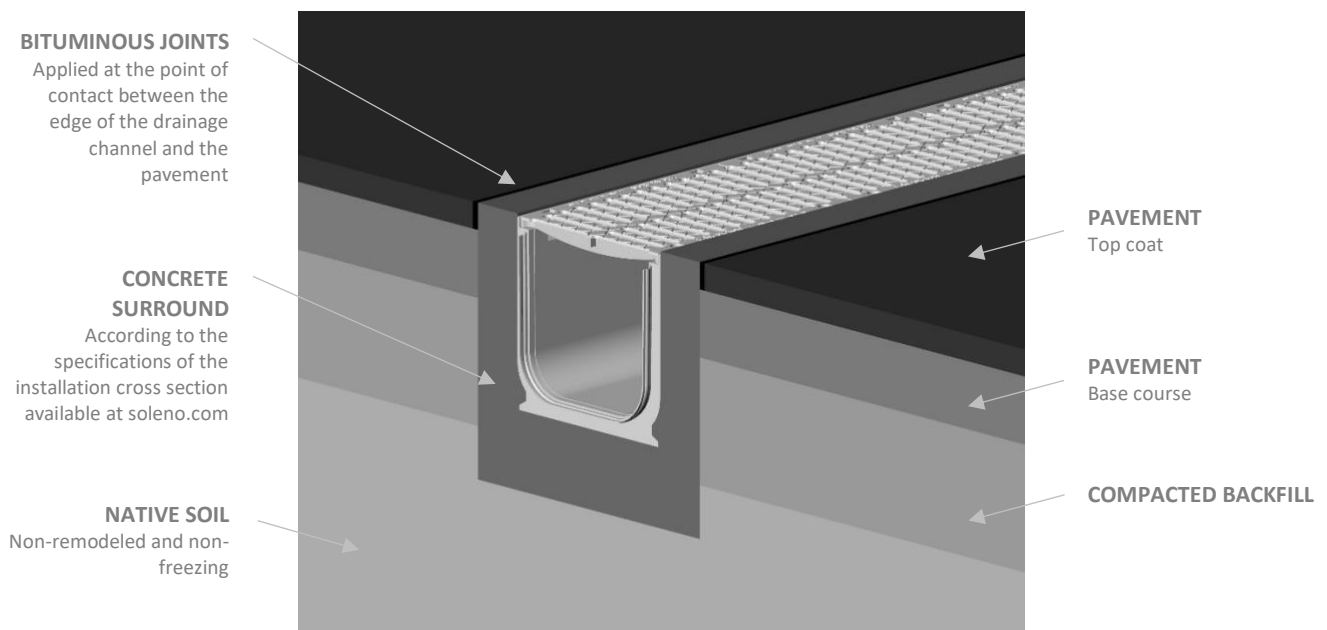

STEP 3 : FINISHING (SUITE)

DETAIL 3 : CONCRETE PAVEMENT

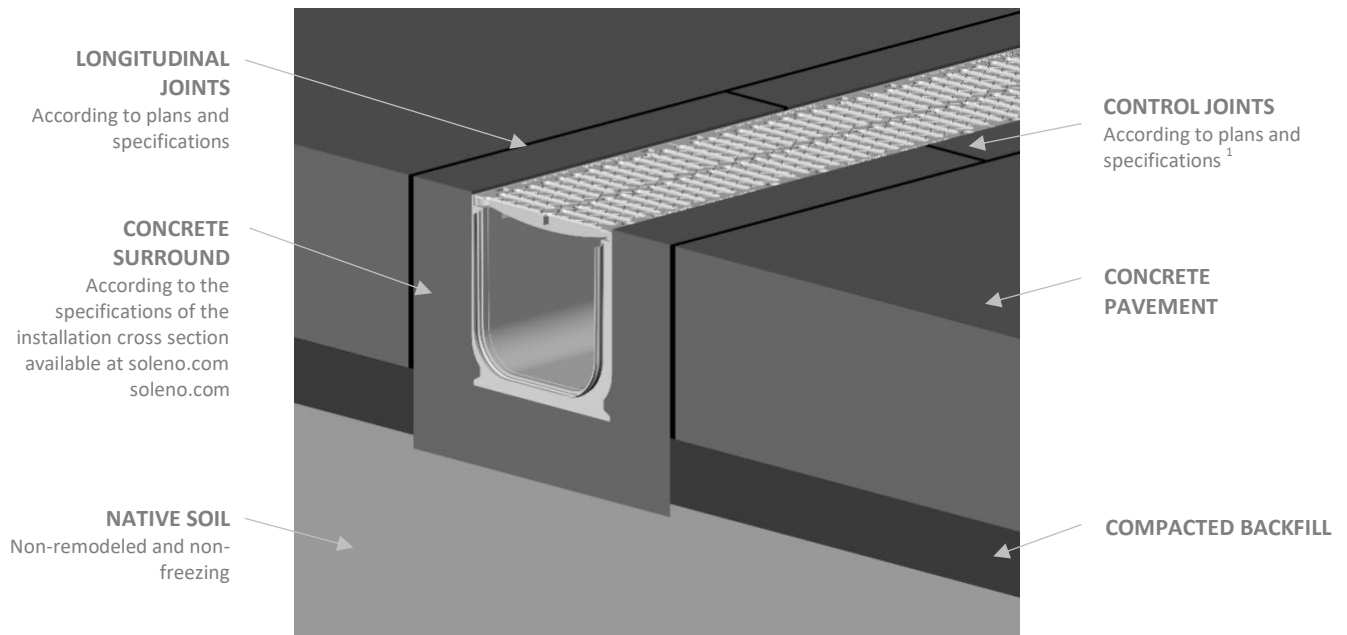

¹ Please refer to the project designer instructions for the optimum distance of the control joints. Soleno recommends control joints at least every 10 meters.