

CDS®

INSTALLATION GUIDE

INSTALLATION INSTRUCTIONS FOR THE CDS® HYDRODYNAMIC SEPARATOR

STEPS

1. Determine the type of installation
2. Before undertaking the work
3. Structure installation
4. Assembly of internal components on site

GENERAL NOTES:

- This guide applies to all CDS models (CDS-3 to CDS-12) made of concrete or HDPE.
- At all times for concrete CDS-7 to CDS-12 models, and for any other model if specified, refer to section 4: Assembly of internal components on site.

STEP 1

DETERMINE THE TYPE OF INSTALLATION

Follow steps 2 and 3 of this guide for every CDS model.

Step 4 concerns concrete models CDS-7, CDS-8, CDS-10 et CDS-12, as they will require on-site assembly of the internal components by the contractor.

NOTE: For all available HDPE CDS models, the internal components will have been pre-installed at the factory.

STEP 2

BEFORE UNDERTAKING THE WORK

In case of discrepancy between the instructions contained in this guide and those contained in the plans and specifications, please contact your Soleno sales representative.

Contact your Soleno sales representative at least 48 hours before work begins. A visit from your authorized Soleno representative is recommended after receipt of the materials on site or before the work begins.

Upon receipt of the materials, ensure that all items required on the slip are delivered and in good condition. Please notify immediately your Soleno representative in case of damage.

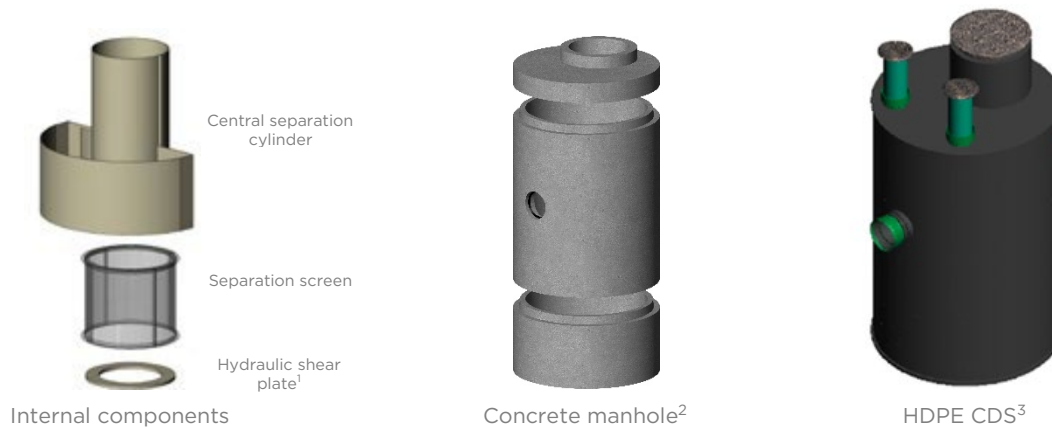

Note 1: The hydraulic shear ring is required for CDS-3 and CDS-4 models only.

Note 2: The concrete manhole will arrive on the site in several sections: the base, one or more intermediate sections and the top slab.

Note 3: HDPE CDS come in a single section with the internal components pre-assembled.

STEP 3 INSTALLATION OF THE STRUCTURE

Ensure you have the necessary equipment to lift the appropriate loads.

CONCRETE CDS

- See Table 1 for the approximate weights of the heaviest component according to the different CDS models. To obtain the precise weight, consult the workshop drawing of the CDS to be installed. Proper lifting points are provided on the structure.
- Refer to the latest version of the BNQ 1809-300 manhole section or the local regulations in force, for the installation of the base course, the manhole and the backfill..
- The concrete manhole sections must be placed according to the sequence indicated on the workshop drawing and two butyl joints must be installed between each section.



- For CDS-10 (octagonal shape), align the alignment arrows of all sections, while respecting the position of the inlet(s) and outlet.



- The final adjustment must be made using riser rings installed in height decreasing order.
- For CDS-3 and CDS-4, install the hydraulic shear plate. Insert it from the top of the cylinder and allow it to settle on the concrete separation slab.

STEP 3

INSTALLATION OF THE STRUCTURE (CONTINUED)

- **TABLE 1**
MAXIMUM WEIGHT OF THE HEAVIEST COMPONENT¹

Models	Nominal diameter		Maximum weight of the heaviest component	
	mm	in	kg	lb
CDS-3	900	36	2000	4409
CDS-4	1200	48	3100	6834
CDS-5	1500	60	5500	12125
CDS-6	1800	72	6000	13227
CDS-7	2100	84	7000	15432
CDS-8	2400	96	11000	24251
CDS-10	3000	120	22000	48502
CDS-12	3600	144	28000	61729

Note 1 : The weights are given for information only. It is important to refer to the shop drawings for the actual weights.

HDPE CDS

- The installation of the CDS will be carried out according to the installation requirements of concrete manhole specified in the BNQ 1809-300 or in the local regulations in force.
- Anti-floatation concrete, poured in place, may be necessary to counter the uplift due to the water table. If this ballast is necessary, its dimensions will be specified on the workshop drawings.
- The lifting cables are pre-installed on the CDS.

STEP 4

ASSEMBLY OF INTERNAL COMPONENTS ON SITE

CONCRETE CDS

Required internal components:

- Fiberglass central separation cylinder
- Stainless steel separation screen
- Deflector pan (if applicable)
- Hydraulic shear plate (if applicable)
- Stainless steel hardware

STEP 4

ASSEMBLY OF INTERNAL COMPONENTS ON SITE (CONT'D)

Tools and equipment required:

- Percussion drill
- 3/8" concrete bit
- Hammer
- Reciprocating saw with a long blade or concrete saw
- 3/4" adjustable wrench
- 9/16" deep socket with ratchet wrench
- Measuring tape
- Caulking gun
- Sikaflex 1a sealant or equivalent approved
- Lifting rings
- Marker

Assembly steps:

1. Unload the fiberglass central separation cylinder and the steel separation screen



2. Place the separation screen on the floor by positioning the green end upwards.



STEP 4

ASSEMBLY OF INTERNAL COMPONENTS ON SITE (CONT'D)

3. Drill the fiberglass separation cylinder.
4. Install the lifting rings on the fiberglass separation cylinder.



5. Lift the fiberglass separation cylinder and place it on the separation screen.



6. While holding in place the fiberglass separation cylinder (with the crane or power shovel), position yourself below the fiberglass part. Adjust the two elements, drill a first hole in the fiberglass and bolt the separation grid onto it. Make sure the separation screen is always centered before moving on to the next hole. Securely tighten the bolts and lock washers.

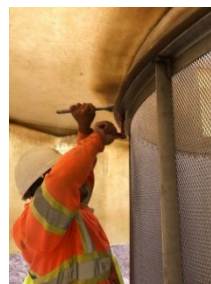

STEP 4 ASSEMBLY OF INTERNAL COMPONENTS ON SITE (CONT'D)

7. Lift the assembly and place it on the separation slab in the concrete CDS.



8. Position the inlet area of the assembly towards the inlet openings, while making sure to press it against the inner wall of the manhole.



9. Cut the fiberglass at the inlet openings. Pay special attention not to damage the fiberglass floor.



STEP 4

ASSEMBLY OF INTERNAL COMPONENTS ON SITE (CONT'D)

10. Drill 4 holes around the opening cut in the fiberglass to fix 4 concrete anchors.



11. Apply a bead of polyurethane elastomer (butyl seal) and complete the sealing with Sikaflex 1a to seal the space between the fiberglass and the wall of the concrete structure of the manhole.



12. Anchor the base of the separation screen to the concrete separation slab.
13. Make sure that the central separation cylinder is not too high for the top slab. Cut the top of the cylinder as needed (see workshop drawing for cylinder height).

STEP 4

ASSEMBLY OF INTERNAL COMPONENTS ON SITE (CONT'D)

14. For CDS with a grated top inlet, a deflector pan and cover will be provided. Install the deflector pan and cover on top of the central separation cylinder. Make sure the open end is facing the inlet area.

Note 1 : The deflector pan is identified with green color in the following image for representative purposes only.

